

## WIND FAST INSTALLATION INSTRUCTION

The installation of the flyscreen should be made by qualified personnel following the instructions listed below.

Use screws or anchors suitable for the type of wall on which the flyscreen will be installed. Make sure that the jambs are parallel and at right-angle; in case of out of square walls make the necessary adjustments to ensure parallelism to the profiles of the flyscreen.

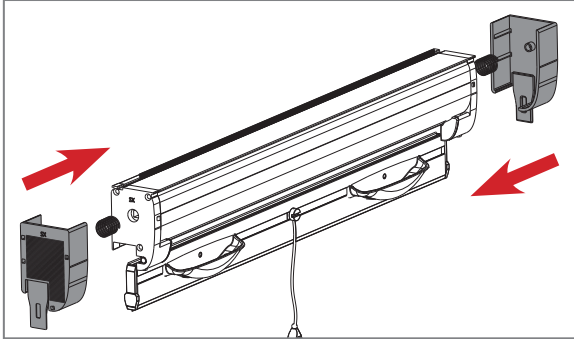

**1** Fix the end-cap to the box paying attention to the position of the spring between the end-cap and the box.

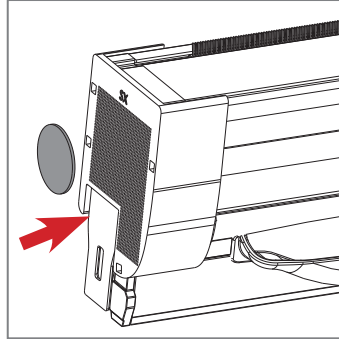

**2** Attach the sticker that you find in the package, to the caps: this will help to keep the box fixed during the installation.

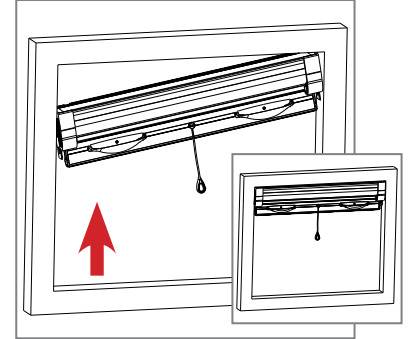

**3** Put the box in the compartment.

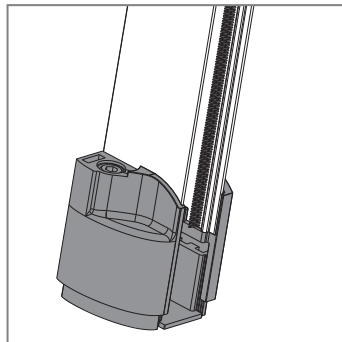
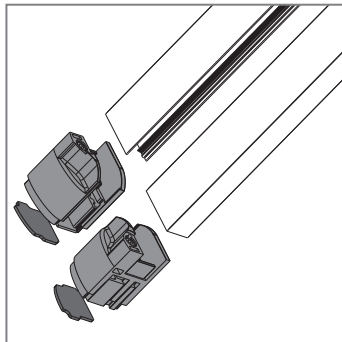

**4** Attach the sticker that you find in the package, to the feet: this will help to keep the guides fixed during the installation. Insert the feet in the guides respecting their way of insertion; the second picture shows the final result.

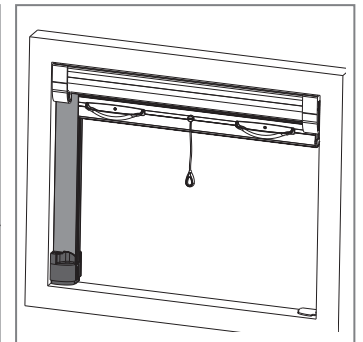
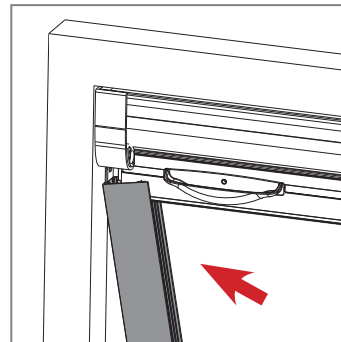

**5** Insert the left and right guide in the conveyor of the caps. Let the sticker adhere to the wall.

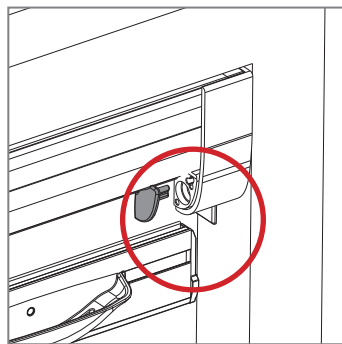
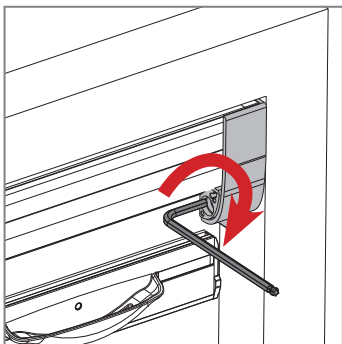

**6** Adjust the expansion caps with the screws. Let the caps adhere to the walls to correct any unevenness of the wall. Insert the cap in its space.

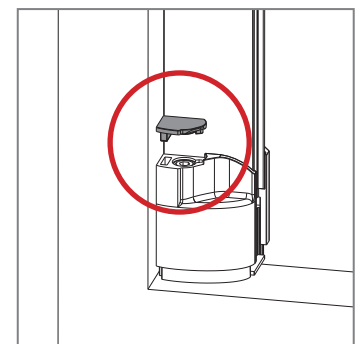
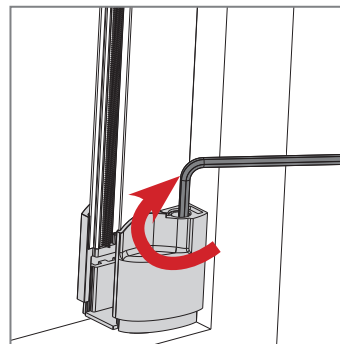

**7** Adjust the expansion feet with the screws. Let the feet adhere to the wall to correct any unevenness. Insert the cap in its space on the feet.

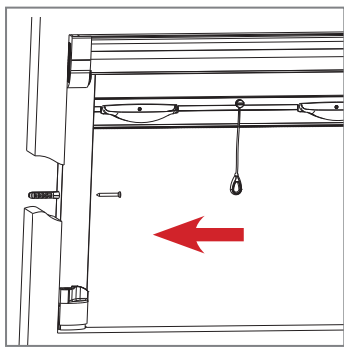

**8** We suggest you to fix the guides to ensure a greater stability to the insect screen.

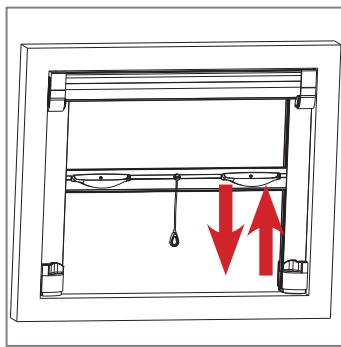

**9** Verify the proper operation of the insect screen.

## PRODUCT INFORMATION

### USE • MAINTENANCE • GUARANTEE

This document is an integral part of the product and is intended for the benefit of all persons using the screen (users + installation and maintenance operators).

All the instructions listed in this document comply with the EU Machinery Directive and provides for the correct use, installation and maintenance of the screen, with the aim of avoiding damage to persons and to the product.

**MV LINE would like to congratulate you on your purchase of this insect screen.**

This guide will help you appreciate the advantages of this screen and assist you during the use, installation and maintenance phases. The company reserves the right to implement partial or complete modifications without prior notice and declines any responsibility in relation to any possible inaccurate or incomplete information. This guide is the property of MV LINE.

**Reproduction (even partial) of this document is expressly prohibited without prior authorisation from MV LINE.**

#### INTENDED USE

The insect screen is intended, as its name would suggest, to act as a protective screen against intrusive insects in the room or area where it has been located. Any other use shall be considered improper. The manufacturer will not be held responsible for damage arising from improper, erroneous and irrational use.

#### PACKAGING, MOVEMENT AND TRANSPORT

- The screens are packaged in transparent bags, cardboard and polyethylene wrapping which protect the unit during transport.
- The screen can be moved by hand and does not require any special equipment to facilitate movement.
- Please take every precaution to avoid any possible damage to the screen.
- After removing the packaging, check that the screen is in perfect condition and that there are no visibly damaged parts. If in doubt, do not use the screen and contact the supplier.

#### ATTENTION!!!

Packaging materials must not be left within the reach of children.

#### USE

Avoid use (opening and closing of the screen) by children.

#### MAINTENANCE

Regularly clean the magnetic parts using a damp cloth.

- In the case of wear and tear, lubricate the bearings using a silicone spray.
- All extraordinary maintenance operations must be carried out by suitably qualified personnel.
- Spare-parts are available from retailers or directly from MV LINE.

#### DISASSEMBLY AND DECOMMISSIONING

Before disassembling the screen, please consult the instructions manual. The screen does not contain dangerous materials. There are no specific guidelines for decommissioning or disposal.

#### GUARANTEE

Do not disassemble apparently malfunctioning parts or accessories on your

own initiative, please contact the retailer who shall organise technical support and spare-parts, failure to do so will affect the conditions of the guarantee. The guarantee includes the complete or partial replacement of the unit or parts in the case of functional issues arising from manufacturing defects and is exempt from damage and deterioration caused by the customer.

**In order to use the guarantee you must copy the INSECT SCREEN CODE as displayed on the label attached to the screen housing into the white space below (see fac-simile fig. 1) and attach the relevant proof of purchase (receipt or invoice).**

This screen is guaranteed by MV LINE for a period of 24 months.

Code:

Find and copy the code displayed on the label attached to the screen housing as shown here.



### Declaration of Performance

The undersigned **MV LINE s.p.a.**  
Via Umbria - Lotto 69 70021 Acquaviva delle Fonti (BA), Italy  
Hereby declares that the product:

### WIND FAST

complies to the following EU directives (including all applicable modifications):  
Machinery Directive 89/392/CEE and Norm UNI EN 13561 Appendix ZA.1

Year of CE marking: 2017.

Acquaviva delle Fonti, 01.01.2017

**CE** EN 13561  
06  
MV LINE s.p.a.  
Via Umbria - Lotto 69 70021  
Acquaviva delle Fonti (BA), Italy  
Product: INSECT SCREEN  
Class: NPD

Signature  
**Paolo Montanaro**  
(CEO)

